

PUBLICLY
AVAILABLE
SPECIFICATION

IEC
PAS 61755-3-31

Pre-Standard

First edition
2007-02

Fibre optic connector optical interfaces –

Part 3-31:

**Optical interface – 8 degrees angled PC end-face
PPS rectangular ferrule, single mode fibre**



Reference number
IEC/PAS 61755-3-31:2007(E)

Publication numbering

As from 1 January 1997 all IEC publications are issued with a designation in the 60000 series. For example, IEC 34-1 is now referred to as IEC 60034-1.

Consolidated editions

The IEC is now publishing consolidated versions of its publications. For example, edition numbers 1.0, 1.1 and 1.2 refer, respectively, to the base publication, the base publication incorporating amendment 1 and the base publication incorporating amendments 1 and 2.

Further information on IEC publications

The technical content of IEC publications is kept under constant review by the IEC, thus ensuring that the content reflects current technology. Information relating to this publication, including its validity, is available in the IEC Catalogue of publications (see below) in addition to new editions, amendments and corrigenda. Information on the subjects under consideration and work in progress undertaken by the technical committee which has prepared this publication, as well as the list of publications issued, is also available from the following:

- **IEC Web Site** (www.iec.ch)
- **Catalogue of IEC publications**
The on-line catalogue on the IEC web site (www.iec.ch/searchpub) enables you to search by a variety of criteria including text searches, technical committees and date of publication. On-line information is also available on recently issued publications, withdrawn and replaced publications, as well as corrigenda.
- **IEC Just Published**
This summary of recently issued publications (www.iec.ch/online_news/justpub) is also available by email. Please contact the Customer Service Centre (see below) for further information.
- **Customer Service Centre**
If you have any questions regarding this publication or need further assistance, please contact the Customer Service Centre:

Email: custserv@iec.ch
Tel: +41 22 919 02 11
Fax: +41 22 919 03 00

PUBLICLY
AVAILABLE
SPECIFICATION

IEC
PAS 61755-3-31

Pre-Standard

First edition
2007-02

Fibre optic connector optical interfaces –

Part 3-31:

**Optical interface – 8 degrees angled PC end-face
PPS rectangular ferrule, single mode fibre**

© IEC 2007 — Copyright - all rights reserved

No part of this publication may be reproduced or utilized in any form or by any means, electronic or mechanical, including photocopying and microfilm, without permission in writing from the publisher.

International Electrotechnical Commission, 3, rue de Varembé, PO Box 131, CH-1211 Geneva 20, Switzerland
Telephone: +41 22 919 02 11 Telefax: +41 22 919 03 00 E-mail: inmail@iec.ch Web: www.iec.ch



Commission Electrotechnique Internationale
International Electrotechnical Commission
Международная Электротехническая Комиссия

PRICE CODE

J

For price, see current catalogue

INTERNATIONAL ELECTROTECHNICAL COMMISSION

FIBRE OPTIC CONNECTOR OPTICAL INTERFACES –

**Part 3-31: Optical interface – 8 degrees angled PC end-face
PPS rectangular ferrule, single mode fibre**

FOREWORD

- 1) The International Electrotechnical Commission (IEC) is a worldwide organization for standardization comprising all national electrotechnical committees (IEC National Committees). The object of IEC is to promote international co-operation on all questions concerning standardization in the electrical and electronic fields. To this end and in addition to other activities, IEC publishes International Standards, Technical Specifications, Technical Reports, Publicly Available Specifications (PAS) and Guides (hereafter referred to as "IEC Publication(s)"). Their preparation is entrusted to technical committees; any IEC National Committee interested in the subject dealt with may participate in this preparatory work. International, governmental and non-governmental organizations liaising with the IEC also participate in this preparation. IEC collaborates closely with the International Organization for Standardization (ISO) in accordance with conditions determined by agreement between the two organizations.
- 2) The formal decisions or agreements of IEC on technical matters express, as nearly as possible, an international consensus of opinion on the relevant subjects since each technical committee has representation from all interested IEC National Committees.
- 3) IEC Publications have the form of recommendations for international use and are accepted by IEC National Committees in that sense. While all reasonable efforts are made to ensure that the technical content of IEC Publications is accurate, IEC cannot be held responsible for the way in which they are used or for any misinterpretation by any end user.
- 4) In order to promote international uniformity, IEC National Committees undertake to apply IEC Publications transparently to the maximum extent possible in their national and regional publications. Any divergence between any IEC Publication and the corresponding national or regional publication shall be clearly indicated in the latter.
- 5) IEC provides no marking procedure to indicate its approval and cannot be rendered responsible for any equipment declared to be in conformity with an IEC Publication.
- 6) All users should ensure that they have the latest edition of this publication.
- 7) No liability shall attach to IEC or its directors, employees, servants or agents including individual experts and members of its technical committees and IEC National Committees for any personal injury, property damage or other damage of any nature whatsoever, whether direct or indirect, or for costs (including legal fees) and expenses arising out of the publication, use of, or reliance upon, this IEC Publication or any other IEC Publications.
- 8) Attention is drawn to the Normative references cited in this publication. Use of the referenced publications is indispensable for the correct application of this publication.
- 9) Attention is drawn to the possibility that some of the elements of this IEC Publication may be the subject of patent rights. IEC shall not be held responsible for identifying any or all such patent rights.

A PAS is a technical specification not fulfilling the requirements for a standard but made available to the public.

IEC-PAS 61755-3-31 has been processed by subcommittee 86B: Fibre optic interconnecting devices and passive components, of IEC technical committee 86: Fibre optics.

The text of this PAS is based on the following document:

This PAS was approved for publication by the P-members of the committee concerned as indicated in the following document:

Draft PAS	Report on voting
86B/2386/NP	86B/2436/RVN

Following publication of this PAS, which is a pre-standard publication, the technical committee or subcommittee concerned will transform it into an International Standard.

This PAS shall remain valid for an initial maximum period of three years starting from 2007-01. The validity may be extended for a single three-year period, following which it shall be revised to become another type of normative document or shall be withdrawn.

FIBRE OPTIC CONNECTOR OPTICAL INTERFACES –

Part 3-31: Optical interface – 8 degrees angled PC end-face PPS rectangular ferrule, single mode fibre

1 Scope

This part of IEC 61755 defines certain dimensional limits that an angled PC end-face multi-fibre rectangular ferrule having two guide-holes for positioning two alignment pins and using polyphenylene sulphide (PPS) material with a Young's modulus of less than 20 GPa has to meet in order to comply with specific requirements for interconnections. Ferrules made from the material specified in this document are suitable for use in category C as defined in IEC 61753-1-1.

2 Normative references

The following referenced documents are indispensable for the application of this document. For dated references, only the edition cited applies. For undated references, the latest edition of the referenced document (including any amendments) applies.

IEC 61753-1-1, *Fibre optic interconnecting devices and passive components performance standard – Part 1: General and guidance – Interconnecting devices*

IEC 61754-5, *Fibre optic connector interface – Part 5: Type MT connector family*

IEC 61754-7, *Fibre optic connector interfaces – Part 7: Type MPO connector family*

IEC 61754-10, *Fibre optic connector interfaces – Part 10: Type Mini-MPO connector family*

IEC 61754-18, *Fibre optic connector interfaces – Part 18: Type MT-RJ connector family*

IEC 61755-1, *Fibre optic connector optical interfaces – Part 1: Optical interfaces for single mode non-dispersion shifted fibre – General and guidance*

3 Description

The performance of the optical interface for an angled PC end-face multi-fibre rectangular ferrule is determined by the accuracy with which the optical datum targets of two mating ferrules are aligned with each other. There are three conditions affecting the alignment of two optical datum targets, lateral alignment, angular alignment and axial alignment.

The specified end-face parameters in this standard are required to provide physical contact between all fibre cores in the mated rectangular ferrules when the ferrules are placed in the fibre optic connector interfaces described in IEC 61754-5, IEC 61574-7, IEC 61754-10 and IEC 61754-18 and tested to conditions for a controlled environment as defined in category C in IEC 61755-1.

The specified lateral and angular parameters are required to provide the performance grades as specified IEC 61753-1.

Parameters influencing the lateral and angular alignment of the optical fibre axes include

- fibre hole position deviation from designated distance;
- clearance between fibre hole diameter and fibre cladding diameter;
- fibre hole angular misalignment;

- fibre core concentricity relative to the cladding diameter;
- clearance between guide hole diameter and alignment pin diameter;
- the amount of angled PC polishing in axial direction.

Parameters influencing the axial alignment of the optical fibre axes include

- end-face flatness;
- end-face angle in the X-axis;
- end-face angle in the Y-axis;
- fibre protrusion/undercut;
- maximum difference in fibre height among all fibres;
- maximum adjacent fibre height differential.

Ferrule compression force and ferrule material shall be considered together with these parameters.

4 Optical interface parameters

This standard defines the dimensional limits of the angled PC end-face multi-fibre rectangular ferrule with single mode fibres. It is applicable for up to 12 fibres with an alignment pitch of 0,25 mm.

The optical interface parameters are defined as shown in Figures 1, 2 and 3.

The parameter values are described as shown in Tables 1 to 4.

4.1 End-face parameters related to attenuation

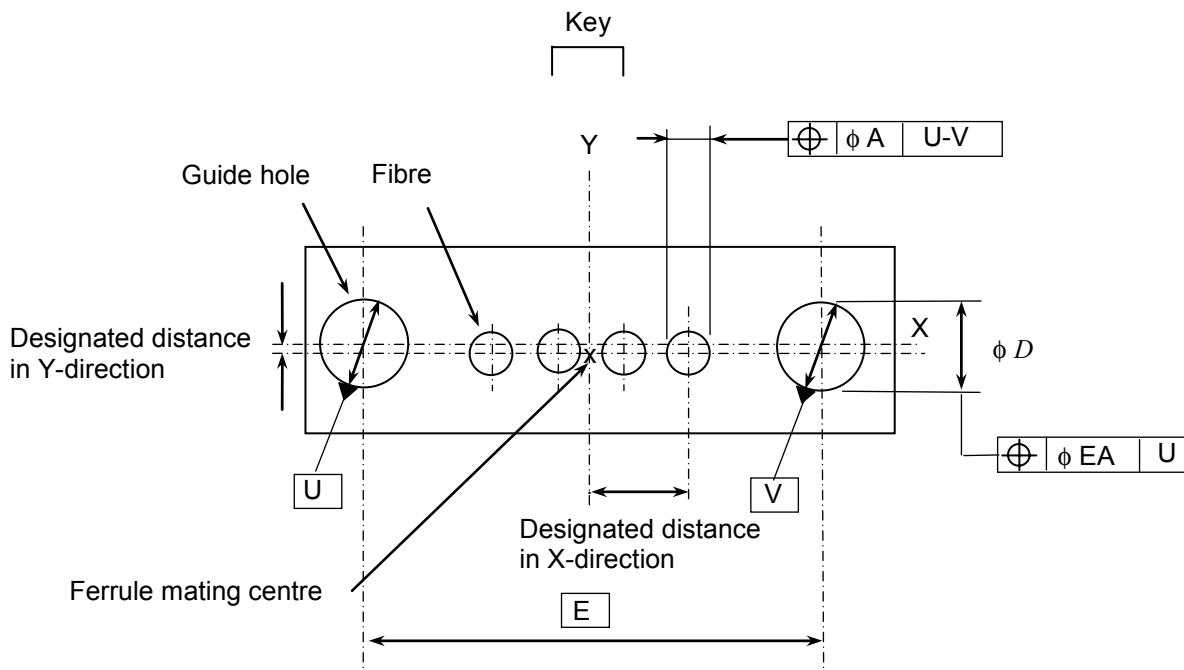

Figure 1 – Fibre core lateral location

The X-axis is the the line passing through two guide hole centres.

The Y-axis is the line perpendicular to the X-axis and passing through the midpoint of the line connecting the two guide hole centres.

The designated distance in the X-direction is $(0,125 + (n/2 - 1) \times 0,25)$ mm in the right and left directions, where $n = 2, 4, 8, 10, 12$ (number of fibres) for 6,4 mm × 2,5 mm rectangular ferrules, and $n = 2, 4$ for 4,4 mm × 2,5 mm rectangular ferrules.

The designated distance in the Y-direction is (basic dimension of guide hole diameter D – basic dimension of alignment pin diameter I)/2.

Here, the basic dimension of I is 0,6985 mm. The basic dimension of D is a nominal value which is an average of the minimum and maximum values in Tables 1 and 2, and it will be slightly shifted according to the designed minimum and maximum values.

A is the position tolerance of the fibre-core centre.

EA is the position tolerance of the guide-hole centre.

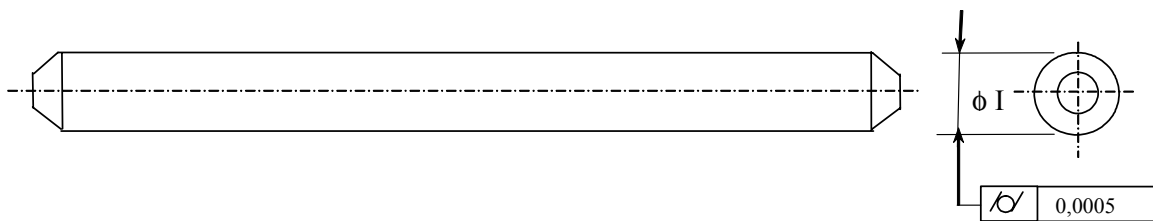
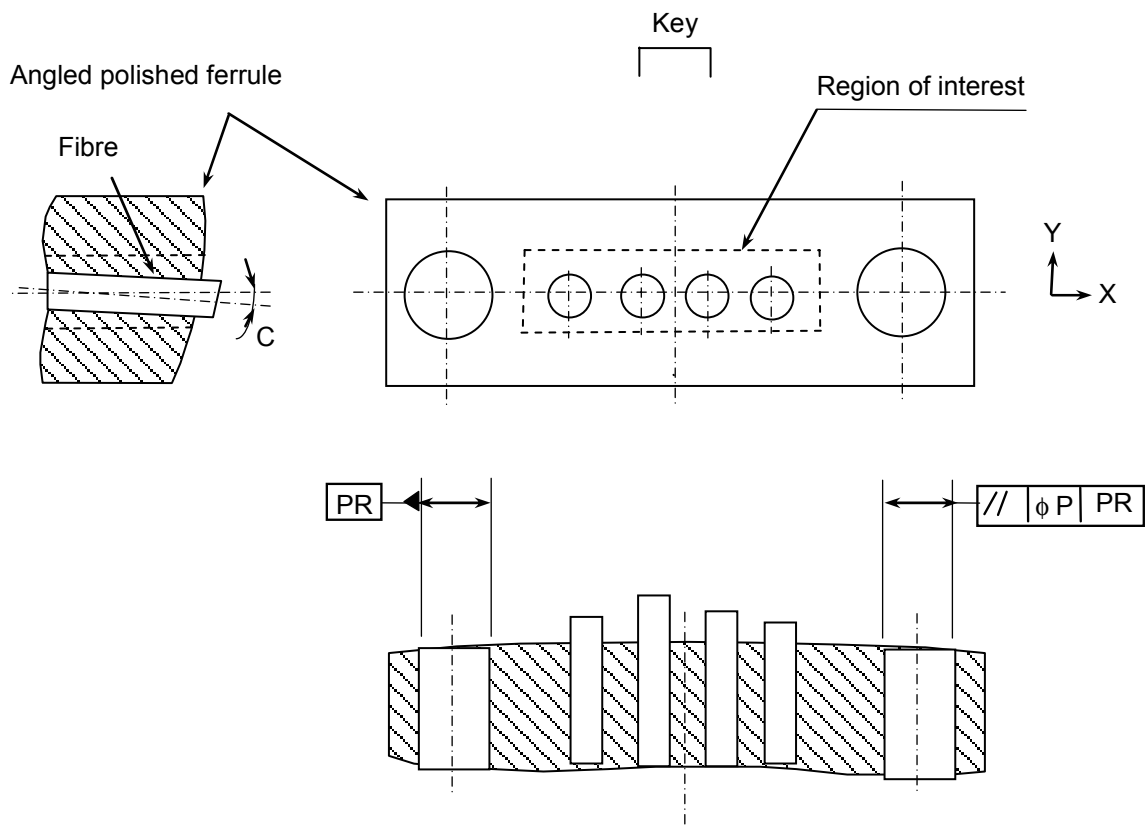

Figure 2 – Alignment pin



NOTE The region of interest is set on the ferrule surface and defined by a rectangular region which is chosen to cover the intended contact zone of the ferrule end face when the ferrules are mated.

Figure 3 – End-face parameters related to attenuation

Table 1 – Optical interface parameter values related to attenuation for 4,4 mm x 2,5 mm rectangular ferrules with two fibres fixed

Reference	Parameter values						Notes
	Grade B		Grade C		Grade D		
	Minimum mm	Maximum mm	Minimum mm	Maximum mm	Minimum mm	Maximum mm	
A	0	0,0015	0	0,0020	0	0,0032	
C	-	0,2°	-	0,2°	-	0,5°	
D	0,6990	0,6996	0,699	0,700	0,699	0,700	1
E	2,6		2,6		2,6		Basic dimension, 1
EA	-	0,004	-	0,004	-	0,004	1
P	-	0,002	-	0,002	-	0,002	2,3
I	0,6984	0,6986	0,698 mm	0,699	0,698 mm	0,699	

NOTE 1 Each guide-hole should accept a gauge pin as shown in Figure 4 of IEC 61754-10 and IEC 61754-18 to a depth of 5,5 mm with a maximum force of 1,7 N. In addition, two guide-holes should accept a gauge as shown in Figure 5 of IEC 61754-10 to a depth of 5,5 mm with a maximum force of 3,4 N.

NOTE 2 These values should be specified in the central surface region surrounding fibres of 0,900 mm wide and 0,675 mm high. Furthermore, the outside surface region should be lower than the central surface region of interest.

NOTE 3 These values should be applied to ferrule materials with a Young's modulus of less than 20 GPa. The ferrule compression force should be 7,8 N minimum and 11,8 N maximum.

Table 2 – Optical interface parameter values related to attenuation for 4,4 mm x 2,5 mm rectangular ferrules with four fibres fixed

Reference	Parameter values						Notes
	Grade B		Grade C		Grade D		
	Minimum	Maximum	Minimum mm	Maximum mm	Minimum mm	Maximum mm	
A			0	0,0020	0	0,0032	
C			-	0,2°	-	0,5°	
D			0,699	0,700	0,699	0,700	1
E			2,6		2,6		Basic dimension, 1
EA			-	0,004	-	0,004	1
P			-	0,002	-	0,002	2,3
I			0,698	0,699	0,698	0,699	

NOTE 1 Each guide-hole should accept a gauge pin as shown in Figure 4 of IEC 61754-10 and 61754-18 to a depth of 5,5 mm with a maximum force of 1,7 N. In addition, two guide-holes should accept a gauge as shown in Figure 5 of IEC 61754-10 to a depth of 5,5 mm with a maximum force of 3,4 N.

NOTE 2 These values should be specified in the central surface region surrounding fibres of 0,900 mm wide and 0,675 mm high. Furthermore, the outside surface region should be lower than the central surface region of interest.

NOTE 3 These values should be applied to ferrule materials with a Young's modulus of less than 20 GPa. The ferrule compression force should be 7,8 N minimum and 11,8 N maximum.

Table 3 – Optical interface parameter values related to attenuation for 6,4 mm × 2,5 mm rectangular ferrules with two fibres fixed

Reference	Parameter values						Notes
	Grade B		Grade C		Grade D		
	Minimum mm	Maximum mm	Minimum mm	Maximum mm	Minimum mm	Maximum mm	
A	0	0,0015	0	0,0020	0	0,0032	
C	-	0,2°	-	0,2°	-	0,5°	
D	0,6990	0,6996	0,699	0,700	0,699	0,700	1
E	4,6		4,6		4,6		Basic dimension, 1
EA	-	0,004	-	0,004	-	0,006	1
P	-	0,002	-	0,002	-	0,002	2,3
<i>I</i>	0,6984	0,6986	0,698	0,699	0,698	0,699	

NOTE 1 Each guide-hole should accept a gauge pin as shown in Figure 2a of IEC 61754-5 to a depth of 5,5 mm with a maximum force of 1,7 N. In addition, two guide-holes should accept a gauge as shown in Figure 2e of IEC 61754-5 to a depth of 5,5 mm with a maximum force of 3,4 N.

NOTE 2 These values should be specified in the central surface region surrounding fibres of 2,900 mm wide and 0,675 mm high. Furthermore, the outside surface region should be lower than the central surface region of interest.

NOTE 3 These values should be applied to ferrule materials with a Young's modulus of less than 20 GPa. The ferrule compression force should be 7,8 N minimum and 11,8 N maximum.

Table 4 – Optical interface parameter values related to attenuation for 6,4 mm × 2,5 mm rectangular ferrules with four, eight ten and twelve fibres fixed

Reference	Parameter values						Notes
	Grade B		Grade C		Grade D		
	Minimum mm	Maximum mm	Minimum mm	Maximum mm	Minimum mm	Maximum mm	
A			0	0,0020	0	0,0032	
C			-	0,2°	-	0,5°	
D			0,699	0,700	0,699	0,700	1
E			4,6		4,6		Basic dimension, 1
EA			-	0,004	-	0,006	1
P			-	0,002	-	0,002	2,3
<i>I</i>			0,698	0,699	0,698	0,699	

NOTE 1 Each guide-hole should accept a gauge pin as shown in Figure 2a of IEC 61754-5 to a depth of 5,5 mm with a maximum force of 1,7 N. In addition, two guide-holes should accept a gauge as shown in Figure 2e of IEC 61754-5 to a depth of 5,5 mm with a maximum force of 3,4 N.

NOTE 2 These values should be specified in the central surface region surrounding fibres of 2,900 mm wide and 0,675 mm high. Furthermore, the outside surface region should be lower than the central surface region of interest.

NOTE 3 These values should be applied to ferrule materials with a Young's modulus of less than 20 GPa. The ferrule compression force should be 7,8 N minimum and 11,8 N maximum.

4.2 End-face parameters related to physical contact

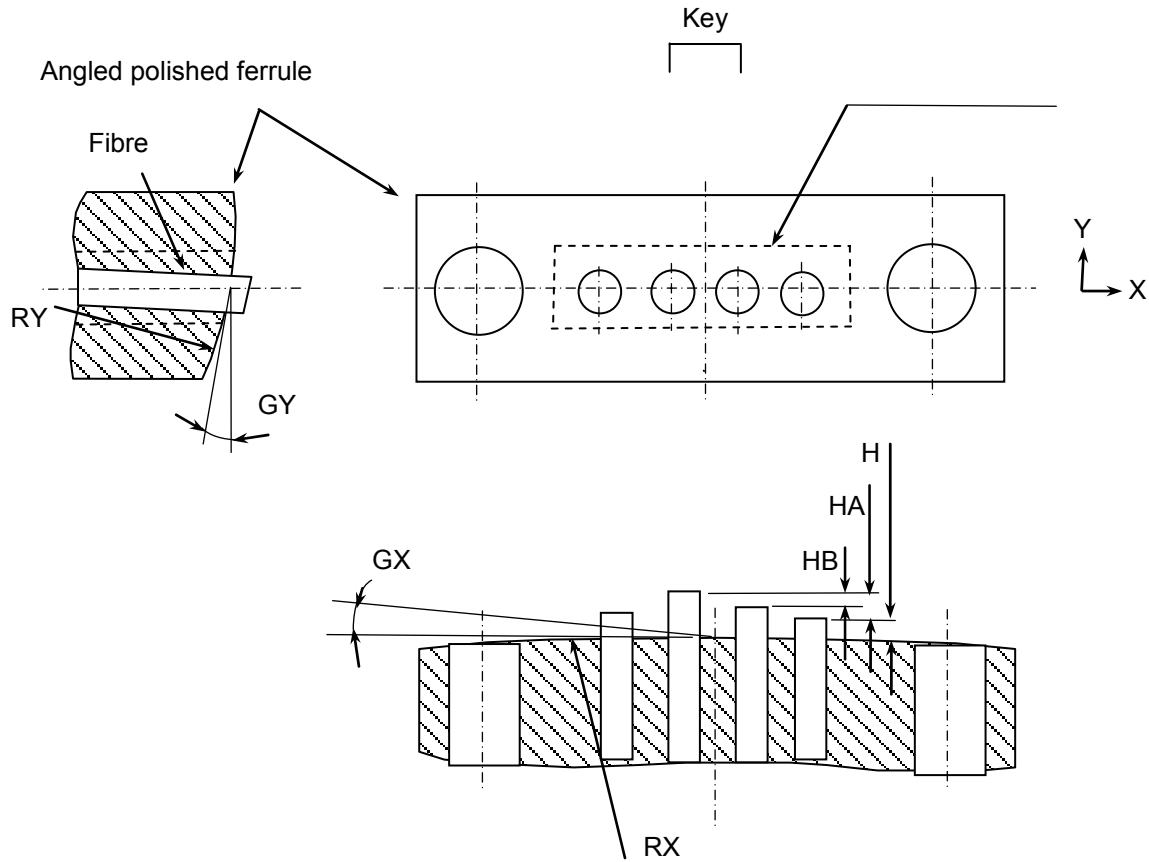

NOTE The region of interest is set on the ferrule surface and defined by a rectangular region which is chosen to cover the intended contact zone of the ferrule end face when the ferrules are mated.

Figure 4 – End-face geometry parameters related to physical contact

H is the fibre protrusion/undercut.

HA is the maximum difference in fibre height among all fibres.

HB is the maximum adjacent fibre height differential.

Table 5 – End-face geometry parameters related to physical contact

Reference	Fibre count: 2, 4, 8, 10 and 12		Notes
	Minimum mm	Maximum mm	
RX	2 000	-	1, 2
RY	5	-	1, 2
GX	-0,2°	+0,2°	1, 2
GY	7,8°	8,2°	1, 2
H	+0,001	+0,0035	1, 2
HA	-	0,0005	1, 2
HB	-	0,0003	1, 2

NOTE 1 These values should be specified in the central surface region surrounding fibres of 2,900 mm wide and 0,675 mm high. Furthermore, the outside surface region should not be higher than the central surface region of interest.

NOTE 2 These values should be applied to ferrule materials with a Young's modulus of less than 20 GPa. The ferrule compression force should be 7,8 N minimum and 11,8 N maximum.

Annex A (informative)

Relationship between single-channel and multifibre connectors with two to 12 fibres

In this specification, attenuation grades are applied to individual channels, but as the real products in this specification are multi-channel connectors the performance relationship between multi-channel connectors and single-channel connectors is described below.

The Grade C rectangular ferrule connector core alignment specifications for 4-12 fibres meet requirements for Grade B performance at the single-channel level. A population of fibre links interconnected via 12-fibre rectangular ferrules will yield $\leq 0,25$ dB attenuation for >97 % of all channels with a mean of $\leq 0,12$ dB. Therefore, by the single-mode connector grade definitions specified in IEC 61753-1, a grade C, 12-fibre rectangular ferrule with only one populated fibre is classified as a Grade B connector. However, the intra-connector channel grouping of fully populated multi-fibre connectors results in the following theoretical, worst-case connector attenuation yield percentage for a completely random core alignment distribution.

Multi-fibre connector attenuation yield % = {single-channel attenuation yield %}ⁿ where n = the number of populated fibres per ferrule.

Figure A.1 Illustrates a population of channels individually along with the theoretical worst-case performance by connector for the same population grouped in 12-fibre connectors.

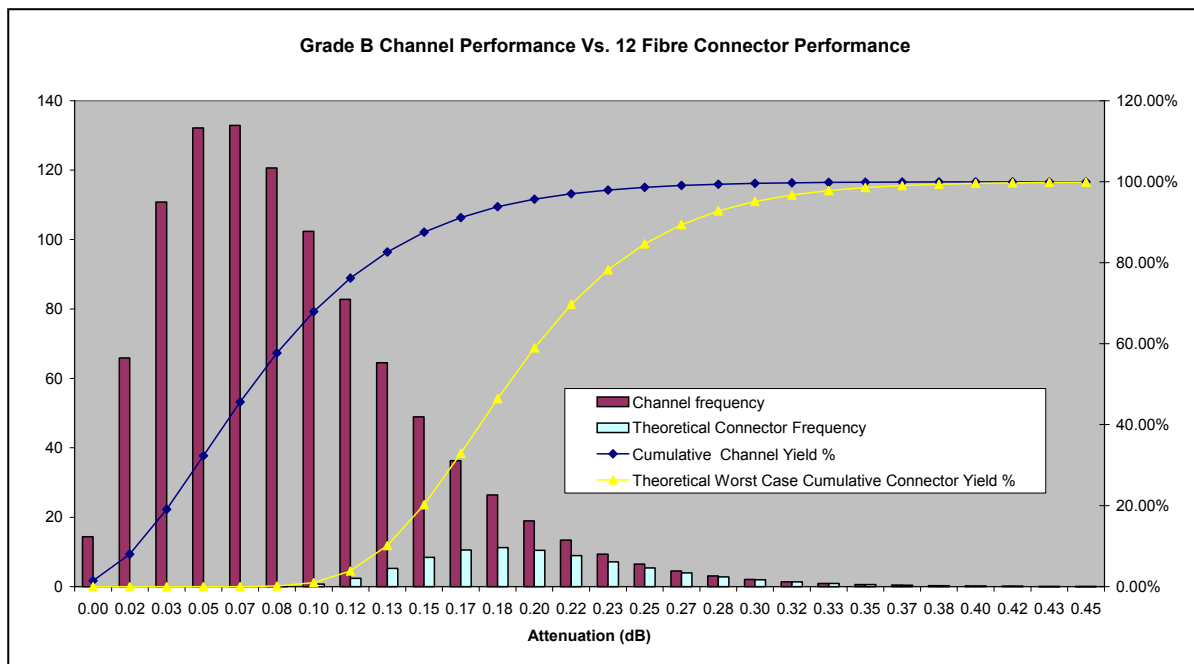

**Figure A.1 – Relationship between single-channel and multifibre connector
with two to 12 fibres**

ISBN 2-8318-8974-X



9 782831 889740

ICS 33.180.20
